

PHYSICS

CHEMISTRY  
BIOLOGY

ENGINEERING



LD DIDACTIC

# DRIVE TECHNOLOGY & ELECTRIC MACHINES

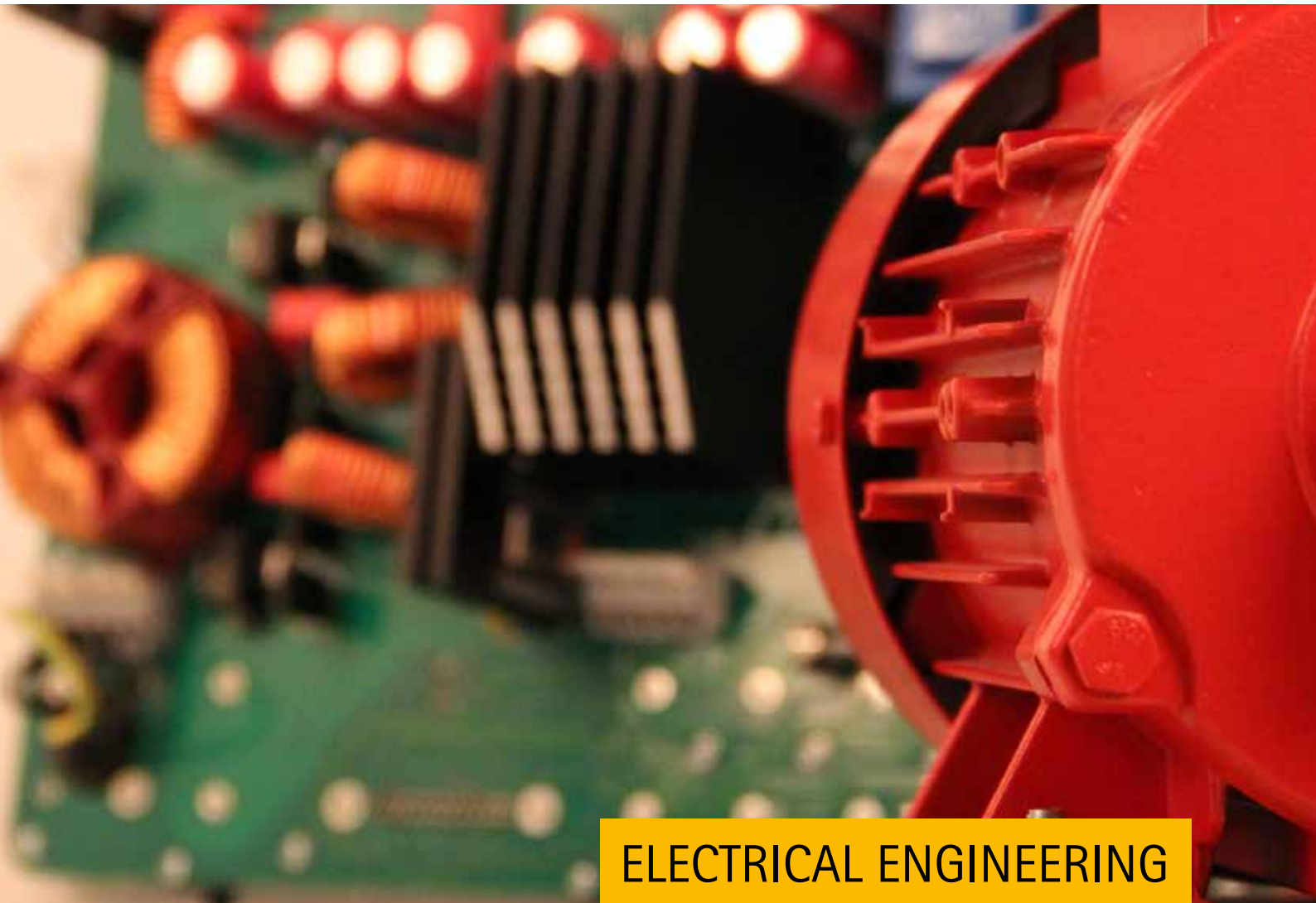

ELECTRICAL ENGINEERING

- TESTING MACHINES
- SIMULATING LOADS
- CONTROL POWER STATIONS

**LEYBOLD®**

## MODERN DRIVE TECHNOLOGY



Electric machines and drives are present everywhere in daily life – whether in vacuum cleaners, drills, conveyor belts or in cars. In fact, the fundamental principals of electric machines have been around for more than 150 years. That said, there has been further technological progress in this field in recent decades, through developments such as Industry 4.0. The specialists in this field are continually being required to broaden their knowledge.

As well as the testing of engines and generators, the new Machine Test System also combines load simulation of machines with direct start-up in the network or for speed-regulated drives.

- Testing machines
  - Motor testing
  - Generator testing
- Load simulation
  - Start-up of asynchronous machines in the network
  - Speed operation with variable drives

- Generator regulation
  - Generators in isolated operation
  - Generators in network operation
- Check mechanics
  - Static analysis
  - Dynamic analysis

The trainees not only learn about the design but also the behaviour and mode of operation of various machine types – from the already well-established to the most modern and highly efficient machines. They are also in the position to analyse the behaviour under various load conditions, calculate the characteristic values and record machine-typical characteristic curves. Knowledge about the effects in electrical networks and the most modern switching devices are also acquired in the process.

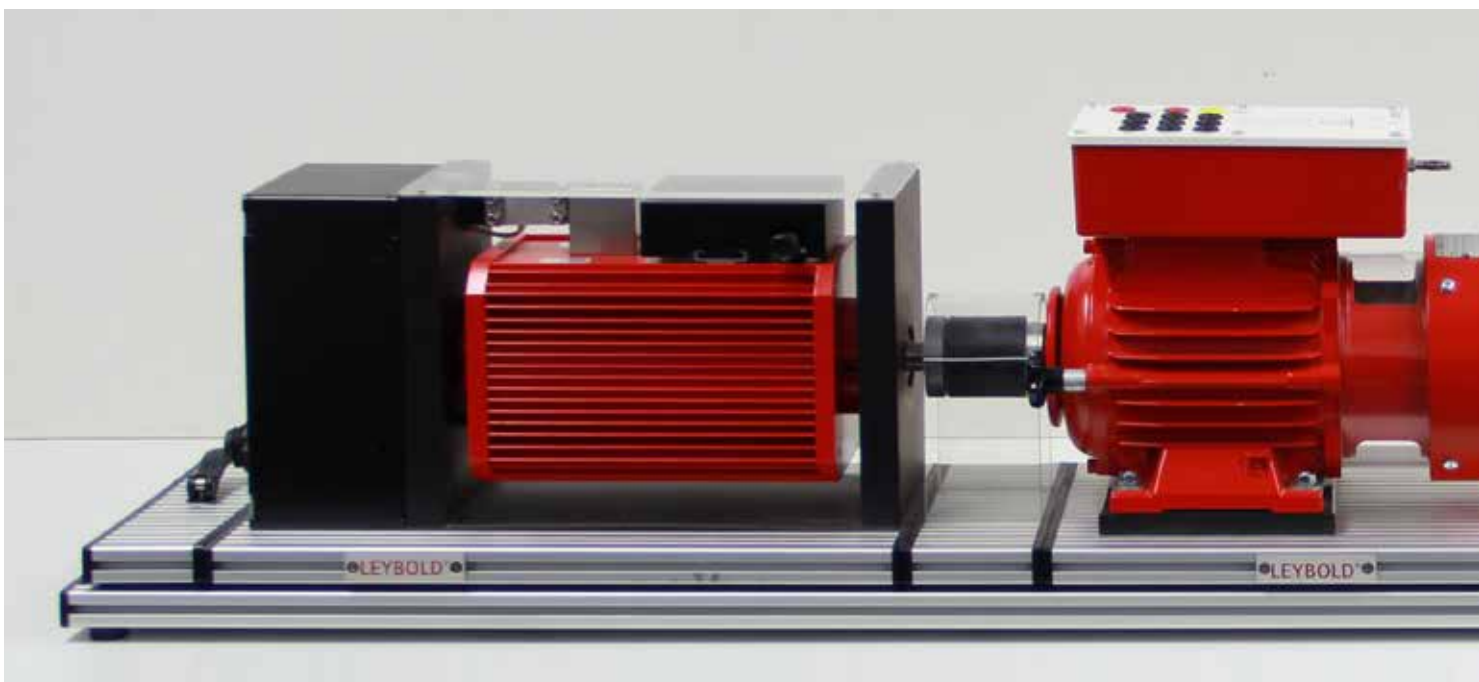

## MACHINE TEST SYSTEM

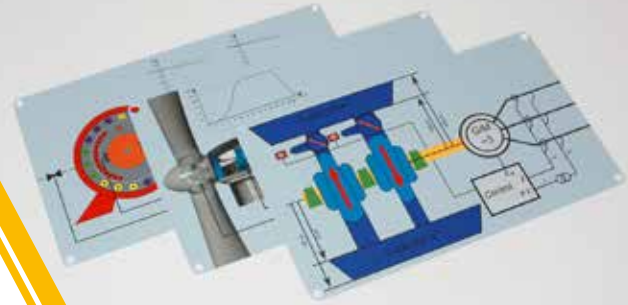

The innovative LEYBOLD Machine Test System allows the analysis of DC, AC and three-phase electric machines of the 300 W class (1.0 kW also available) that are all industrially designed and didactically prepared. The test subjects can be replaced rapidly and easily. In doing so, the safety requirements of the Machinery Directives are fulfilled.

### LEARNING FIELDS

- Structure and functionality of machines
- Behaviour of machines as a motor
- Behaviour of machines as a generator
- Speed setting options
- Efficiency
- Characteristic curves of motors
- Load simulation
- Speed and load setting options
- Starting and braking
- Characteristic curves of generators
- Idle and short circuit test



## MACHINE TEST CASSY



The Machine Test CASSY is an analysis device combined with a measurement and control device as well as an integrated control unit for the electric dynamometer.

With its functional spectrum, this device combination allows free representation of:

- Machine characteristic curves  $n/T$  or  $T/n$
- Diagrams over time (such as machine start-up)
- X-Y-diagrams (hysteresis of transformers)

The CASSY can be used both as a TPS framework system and as a tabletop unit.

Step by step, trainees are guided through the menu items – starting with selection of the machine, continuing with connection of the machine and connection with the measuring system right up to the start of measurement. All measurement results can be shown on the display. The WiFi connection function allows measurements and measurement results to be shared and accessed on student devices such as tablets or smartphones.

### PRODUCT HIGHLIGHTS

- ★ Automated detection of the machine
- ★ Time-synchronous measurement of torque, speed, voltage, current number, voltage, current, phases, angle & frequency
- ★ Representation of the measurement as a diagram or table
- ★ Basic analyses already possible on the control unit without possible without software (e.g. approximation line & parabola)
- ★ All measured values of the machine are standard method (EN DIN 60034-2-1) are carried out

The new system offers:

- Automated detection of the machine
- Temperature monitoring of the tested motor and electric dynamometer
- Monitoring of the entire test set-up
- Adaptation of all maximum test values to the machine data

The Machine Test CASSY can be used as a manual, stand-alone measuring device without a PC or software. Further representation options are provided in combination with the software CASSY Lab 2: the determination of additional parameters and the formula tool allow the calculation of new variables. Results can be saved and inserted into your own documents as a table or graphic.

In addition, free drivers are also available for LabView™ and MATLAB®.

773 2000	Machine Test System 0.3 (complete system)
included products:	
773 1900	Machine Test CASSY 0.3
773 1990	Electrical Dynamometer 0.3
773 108	Coupling / shaft end guard 0.3
773 110	Machine Base Unit 90 cm
315 39	Weight with hook 1 kg



## ELECTRICAL DYNAMOMETER

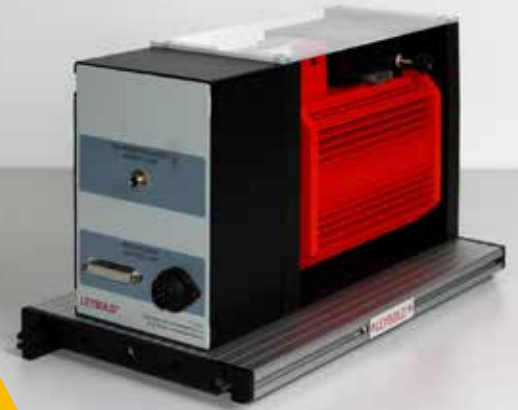

The electric dynamometer is a free-floating asynchronous servo machine for the measurement of electrical and mechanical energy. This is determined directly via an integrated incremental shaft encoder for speed measurement and a torque measurement unit to detect the torque. For didactic reasons and for better comprehension by trainees, the torque is recorded via a visibly-mounted stainless steel bending system with strain gauges. An easy-to-use adjusting unit is available for zero-point comparison of the torque.

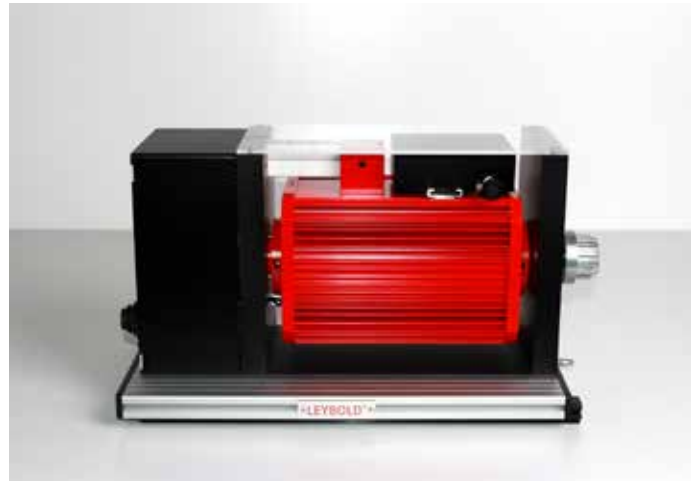

### PRODUCT HIGHLIGHTS

- ★ Didactic torque measurement with zero-point comparison and calibration by external weight
- ★ Rapid torque & speed measurements allow the analysis of start-up behaviour of the electric machines
- ★ Safety loop for shutdown via rapid braking in the event of a fault
- ★ Equipotential bonding via 6 mm spring contacts between dynamometer & control unit



Potential equalisation connection

773 1990

Electrical Dynamometer 0.3

## ELECTRICAL MACHINES FOR MACHINE TEST SYSTEM



### DC COMPOUND MACHINE



- Direct current compound engine for motor and generator operations
- Can be used as a shunt machine, series machine or as a compound machine
- Series winding with tap for compounding and shunt winding

### UNIVERSAL MOTOR



- Universal motor as series machine
- Operation with alternating or direct current

### CAPACITOR MOTOR R



- Single-phase alternating motor
- Includes a starting relay, a starting capacitor and an operating capacitor

### SQUIRREL CAGE MOTOR 400/690



- Three-phase asynchronous motor
- 400/690 V  $\Delta/Y$

### SQUIRREL CAGE MOTOR D



- Three-phase asynchronous motor
- Tapped winding

### SQUIRREL CAGE MOTOR SW



- Three-phase asynchronous motor
- 2 separated coils

773 186	DC Compound Machine
773 200	Universal Motor
773 204	Capacitor Motor R
773 212	Squirrel Cage Motor 400/690
773 224	Squirrel Cage Motor D
773 226	Squirrel Cage Motor SW
773 228	Multi-Function Machine
773 233	Slip Ring Motor

773 2104	Squirrel Cage Motor 230/400
773 236	Synchronous Machine SP
773 237	Synchronous Machine SR
773 340	Synchronous Machine Permanent Excitation IPM
773 2201	Squirrel Cage Motor Basic 230/400/0.3
773 2203	Squirrel Cage Motor Basic 400/690/0.3
773 2108	Squirrel Cage Motor 230/400/0.3 IE3

## AT A GLANCE

### MULTI-FUNCTION MACHINE



- Three-phase multifunction machine with slip ring rotor
- Can be used as an asynchronous or synchronous machine
- For motor and generator operation

### SLIP RING MOTOR



- Three-phase asynchronous motor with slip ring rotor
- Visibility of the slip ring

### SQUIRREL CAGE MOTOR 230/400



- Three-phase asynchronous motor with cage rotor
- 230/400 V  $\Delta/Y$

### SYNCHRONOUS MACHINE SP



- Three-phase synchronous machine
- Salient pole rotor and damper cage
- Visibility of the slip ring

### SYNCHRONOUS MACHINE SR



- Three-phase synchronous machine
- Solid-pole rotor and damper cage
- Visibility of the slip ring

### SYNCHRONOUS MACHINE PERMANENT EXCITATION IPM



- Three-phase synchronous machine with embedded permanent magnets in the rotor
- Visibility of the magnets

### SQUIRREL CAGE MOTOR BASIC 230/400/0.3

- Three-phase asynchronous motor with cage rotor
- Connections on the top in the original terminal box
- Without educational terminal board

### SQUIRREL CAGE MOTOR BASIC 400/690/0.3

- Industrial three-phase asynchronous motor with cage rotor
- Connections on the top in the original terminal box
- Without educational terminal board

### SQUIRREL CAGE MOTOR 230/400/0.3 IE3

- Three-phase asynchronous motor with squirrel cage rotor
- 230/400 V  $\Delta/Y$
- Highly efficient IE3

All listed electrical machines are available in the 0.3 kW class and also in the 1.0 kW power class.

## OVERVIEW OF DISSECTIBLE MACHINES

An insight into the layout and functionality of the electrical machines forms the basic idea for our replaceable rotors.

A ready-to-use electric machine of the 300 W class only results when the rotor and stator components are assembled. The stator housing is mounted on an aluminium base and is thus fully compatible with our 300 W class industrial machines.

Star-grip tension bolts connect the stator and the rotor, allowing rapid exchange of the rotor. The rotors are equipped with non-drive end cap, fan, cover and may also have slip rings, brushes and similar.

The assembled test piece can now be electrically connected and analysed with the Machine Test System. In this way, the characteristic curves can allow deductions to be made about the properties of the respective rotor. Individual exchange of the rotors also means that it is also easily possible to directly compare different types.

In a particularly impressive manner, the savings potential of efficiency machines can be verified and correlated with the additional effort by means the copper cage of the efficiency rotor.

774 7720	3 Phase Stator 0.3
774 7721	Squirrel Cage Rotor 0.3
774 7722	Slip-Ring Rotor 0.3
774 7723	Salient Pole Rotor 0.3
774 7724	Smooth Core Rotor 0.3
774 7725	Reluctance Rotor 0.3
774 7726	DC Shunt Stator 0.3
774 7728	DC Rotor 0.3
774 7729	Squirrel Cage Rotor High Efficiency 0.3
E2.1.3.4	Machines with Rotor Kits (complete set including all necessary accessories)

### PRODUCT HIGHLIGHTS

- ★ Compatible with the 300 W class
- ★ 7 different rotor types
- ★ 2 different stator types



Squirrel Cage Rotor 0.3



Slip-Ring Rotor 0.3



Salient Pole Rotor 0.3



Smooth Core Rotor 0.3



Reluctance Rotor 0.3



DC Shunt Stator 0.3



DC Rotor 0.3



Squirrel Cage Rotor High Efficiency 0.3



## SIMPLE TO USE IN A SAFE WAY

### Easy-to-use Machine Test System

In just a few steps, the trainee can record a characteristic curve with consideration for an asynchronous machine.

#### Step 1: Select the machine

The selection is menu-guided, or is detected by the software in the case of new machines. The machine data can be checked.

#### Step 2: Connection of the machine

The connection diagram informs the trainee about standard-compliant connection for the test set-up.

#### Step 3: Start the machine

In the basic design, the Machine Test CASSY only allows the machine to be started when the safety loop is closed and functional.

#### Step 4: Release, synchronisation & start of measurement

Release is the last check for the trainee that everything is ready for the test. Confirm twice, then the dynamometer is synchronised with the motor. Measurement can be started by pressing the start button.

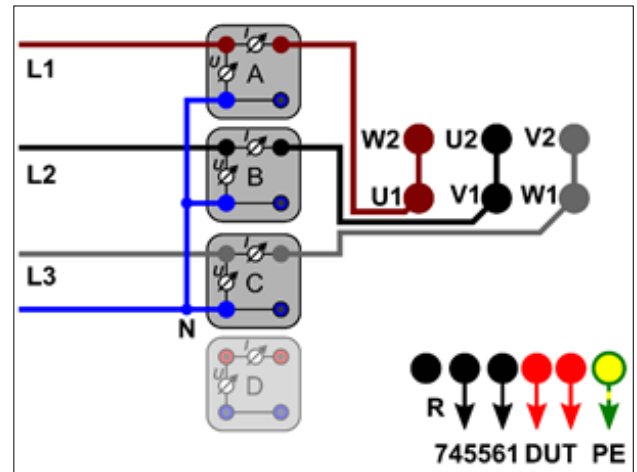

Icon	Parameter
	Machine type: LEYBOLD with aluminium base
	Basic function: Motor without excitation
	Mains type: AC, 3 phases
	Mains voltage: 230/400 V~ / 50 Hz
	Machine: 773 211: Squirrel cage motor 400/690
	Function: Triangle circuit
	Show parameter
	Show connection diagram

Machine Test CASSY

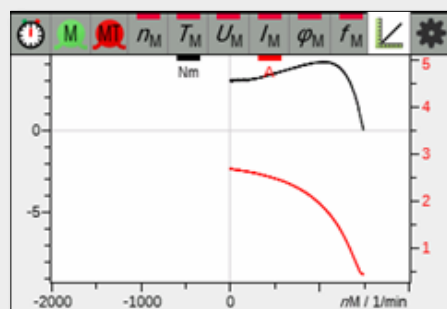

Characteristic curve of a squirrel cage rotor with torque and machine current

CASSY Lab 2

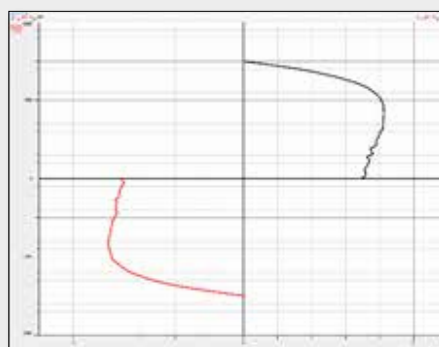

Characteristics of speed over a torque

Diagram in interactive instructions

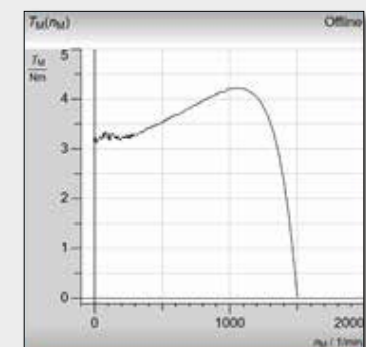

Characteristic curve of a squirrel cage rotor

## CHECK ENGINES WITH SPEED CONTROL



Characteristic curve of a series motor (left-hand rotation)

### Testing electrical machines as motor

For the training of trainees, it is important to know the characteristic curves of a motor. The torque or the efficiency can then be calculated from the measured values and the characteristics of a motor.

Two methods are available for such analyses:

- Speed-regulated characteristic curve recording
- Torque-regulated characteristic curve recording

### Testing motors with a regulated speed

This is the method for recording characteristic curves over the entire speed range. The following motors are suitable for this measurement:

- 3-phase asynchronous motor
- Capacitor motor
- DC motor

All characteristic curves can be recorded for both rotational directions and via the necessary quadrants including the areas of the generators.

Measurement and regulation are two separated processes that are only connected with one another via the start and stop conditions. Hence in

the standard setting, characteristic curves can be recorded with 250 measurement points. For more sophisticated applications, these can be expanded up to 4,000 measurements per characteristic curve.

All measurement range settings are made by selection of the machine and are automatically pre-set. Connection of the electric measurement channels is represented in the connection diagram. This process allows faster switching between the operating modes, e.g. Test machines and Load simulation. All measurement ranges switch automatically, only the testspecific settings and variables must be newly selected.

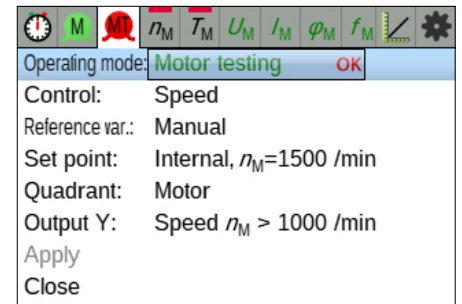

Settings menu for Test Machine

Machine Test CASSY

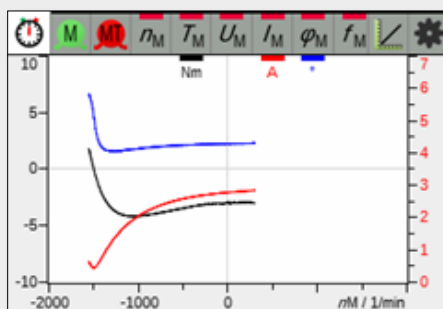

Characteristic curve of a cage rotor, left-hand rotation

CASSY Lab 2

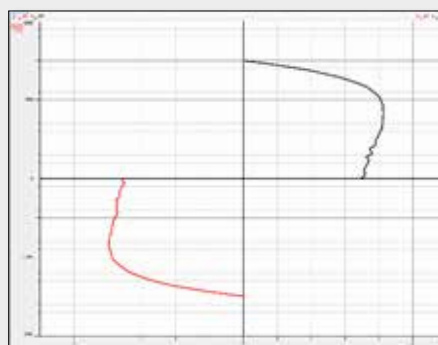

Cage rotor characteristic curve n/T

Diagram in interactive instructions

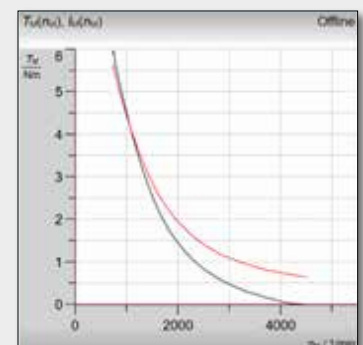

Extract from experiment DC-RS motor

## TESTING MOTORS WITH TORQUE CONTROL



### Testing motors with a regulated torque

Torque regulation is the method for working range analysis and testing a motor. Here, the characteristic values of a motor can be determined and compared with the rating plate.

The following motors

- Synchronous motor
- Permanently excited synchronous motor

can only be tested using this measurement method:

- Determination of the nominal values of all motors
- Testing in accordance with standard methods

The following test methods are available:

- Manual measurement
- Automatic measurement
- Static measurement

In the basic configuration, the following values are recorded for an asynchronous machine:

- Speed  $n_M$ , Torque  $T_M$
- Voltage  $U_M$ , Current  $I_M$ , Phase Shift  $\phi_M$
- Frequency  $f_M$

The trainee can calculate all other values from these values, right up to the efficiency.

For the analysis of drives, the calculated values for mechanical power, apparent power, electrical power, reactive power, excitation power, slippage and efficiency can be released in the configuration.

These measurements do not require any external software.

$n_M / 1/\text{min}$	$T_M / \text{Nm}$
1500	0,441
1500	0,861
1500	1,277
1500	1,714
1500	1,971
1499	2,150

Table with measured values

The integrated WiFi connection means that the trainee can also follow and analyse.

Machine Test CASSY

$n_M / 1/\text{min}$	$T_M / \text{Nm}$	$U_M / \text{V}$	$I_M / \text{A}$
1496	0,480	145,6	1,1091
1476	0,955	145,1	1,1544
1452	1,424	143,5	1,2828
1414	1,908	142,8	1,5135
1376	2,208	141,3	1,7296
1329	2,392	139,8	1,9326

Table with measured values

CASSY Lab 2

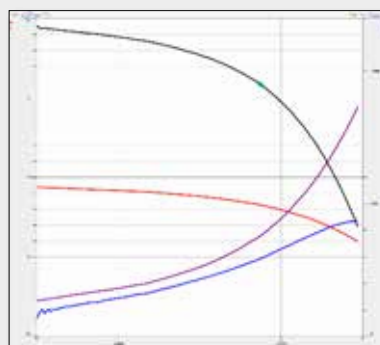

Measurement of a series motor

Layout image in interactive instruction

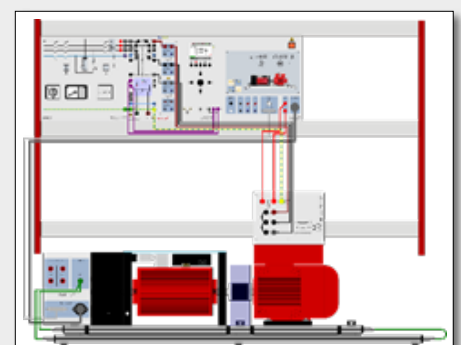

Set-up picture

## TEST & REGULATE GENERATORS

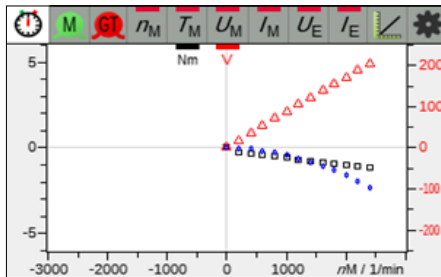

### Generator testing

The generator testing is quite different to the motor test. With the motor test, the dynamometer is a load; with the generator test, it is now a speed-regulated drive.

This test is suitable for synchronous and DC generators.

The following topics can be covered in the „Generator testing“ operating mode:

- Isolated operation
  - Voltage / speed
  - Voltage / exciter current
  - Voltage / last RLC
- Network operation
  - Reactive power / excitation current
  - V-curve stator current / excitation current

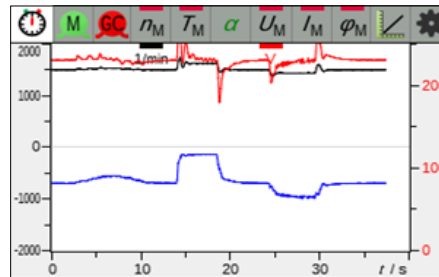

### Generator regulation

Generator regulation deals with the operation of a generator. This can supply just an isolated network or it can be operated in a network.

The following topics can be covered in the „Generator regulation“ operating mode:

- Isolated operation
  - Speed regulator
  - Voltage regulator
  - Static and dynamic load behaviour
  - Network stability of the isolated network
- Network operation
  - Parallel connection of generators, power statics
  - Reactive power statics
  - Reactive power statics
  - Static and dynamic load behaviour

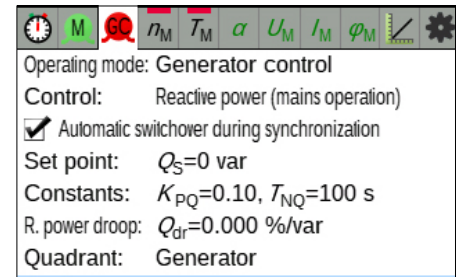

Machine Test CASSY

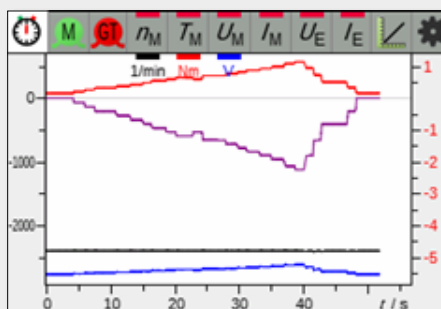

Load behaviour in isolated operation

CASSY Lab 2

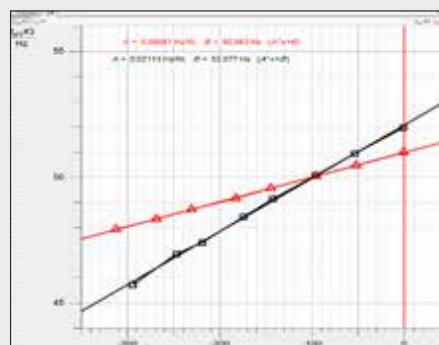

Power statics in network operation

Diagram in an interactive instructions

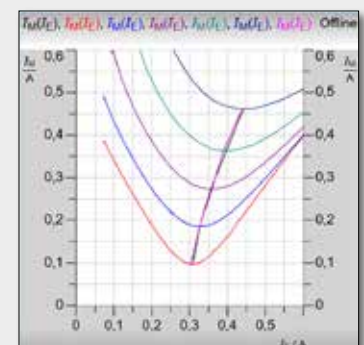

V-curves of a generator

## LOAD SIMULATION

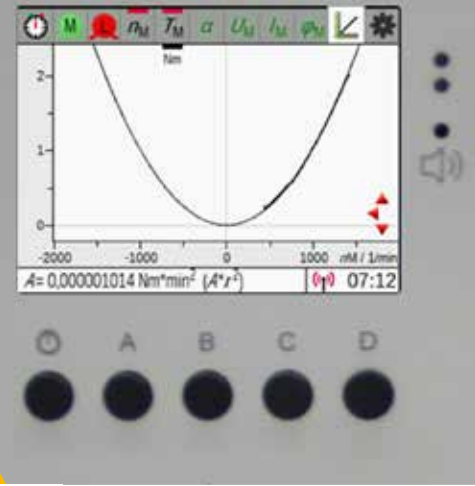

There are two scenarios for load simulation: starting a machine with a motor that is supplied directly from the network, and operation of a machine with a speed-regulated or controlled drive.

### Load simulation in „start-up“ mode

Starting a machine directly from the network is determined by the characteristic curve, by the moment of inertia of the machine and by the machine characteristic curve.

### Load simulation in operational mode

Operational mode is determined for speed-controlled or speed-regulated drives. A torque regulator is active here, which sets the torque that is dependent on the selected function.

### Load simulation dependent on time

A torque-function generator with the basic functions sine, rectangle, triangle and free function and with a frequency of 10 mHz to 2 Hz and  $\pm 3$  Nm.

The following functions can be selected for start and operation:

- Constant torque  $T = const$ 
  - Load-lifting machinery, roller mills, reciprocating compressors
- Linear to speed  $T \sim n$ 
  - Extruders
- Quadratic to speed  $T \sim n^2$ 
  - Pumps, fans, ventilators
- Flywheel  $T \sim \alpha$ 
  - Grindstones, conveyor systems with bulk material
- Sum of all machine functions (real machine)

For operation there is also:

- Inversely proportional to speed:  $T \sim 1/n$ 
  - Lathes and milling machines, winding machines

Machine Test CASSY

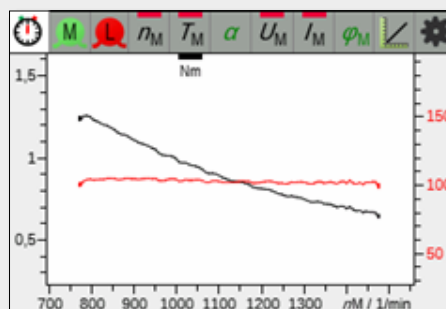

Characteristic curve  $T \sim 1/n$

CASSY Lab 2

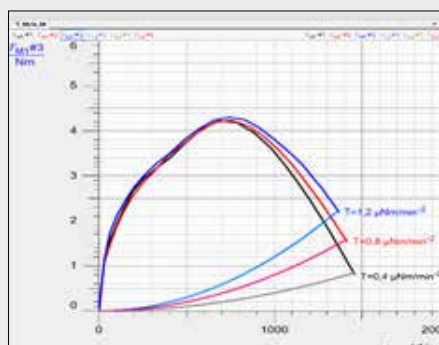

Start characteristic curves for  $T \sim n^2$

Diagram in an interactive instructions

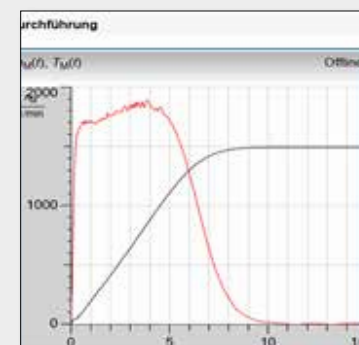

Starting a motor under load

## SPECIFIC EVALUATIONS WITH CASSY LAB 2 FOR DRIVES & ENERGY SYSTEMS

The CASSY Lab 2 software offers a multitude of tools for evaluating and representing measured values in drive and energy technology. This means that e.g. derived values can be calculated using the formula generator. Individual measured values can be displayed without losing the overall view.

The results can be evaluated both as "Computer-based possibility" and also as "Graphic mathematical possibility".

### Computer-based possibilities

- Parameter
- Formula
- Time derivative
- Time integral
- Fourier transformation
- Clarke
- Average
- Histogram

### Graphical mathematical options

- Plot average
- Calculate peak centre
- Implement adaptation
  - Balance line
  - Origin line
  - Parabola
  - Hyperbola 1/x
  - Free adaptation

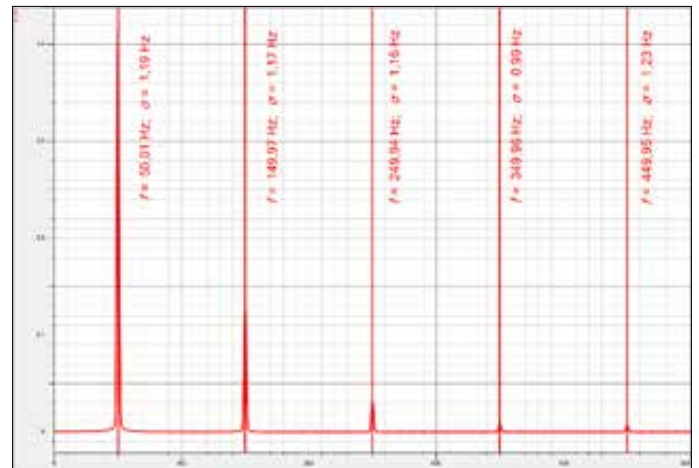

FFT from a transformer current at idle

### PRODUCT HIGHLIGHTS

- ★ Formula editor
- ★ Free representation of the measurements
- ★ Modelling

524 222

CASSY Lab 2 for Drives & Power Systems

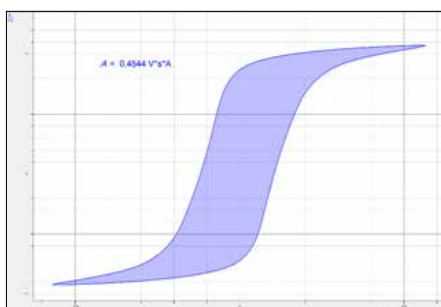

Hysteresis of a transformer with integral of the area

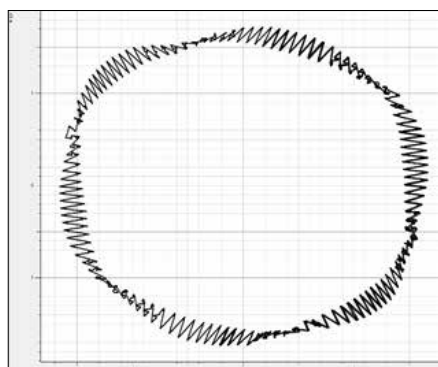

Current vector calculated by the Clarke transformation



Histogram measurement of the moment of inertia of a machine

## SUPPLIES



Motor protection switch, 0.6-1 A



Soft starter 0.3 / 1.0

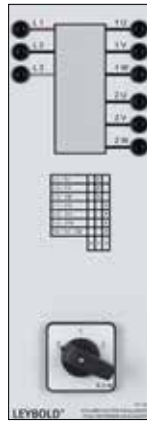

Pole reverser, Dahlander



Motor protection switch, 1-1.6 A

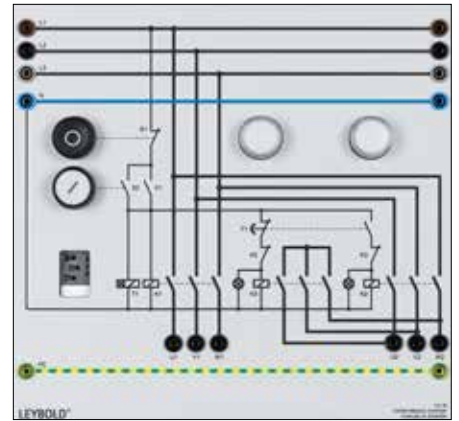

Star-delta starter

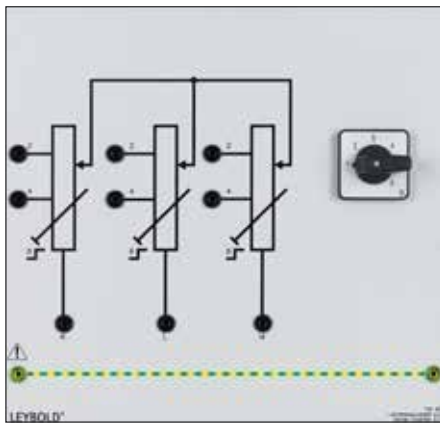

Rotor starter 0.3

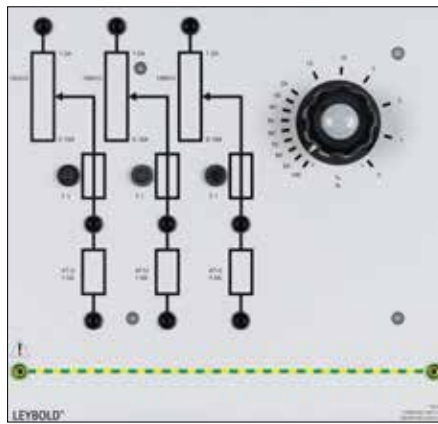

Resistive load 0.3

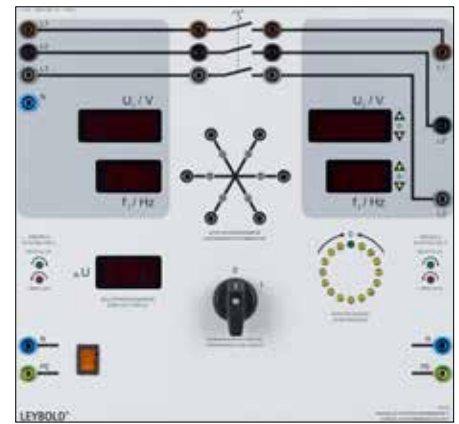

Manual synchronisation unit

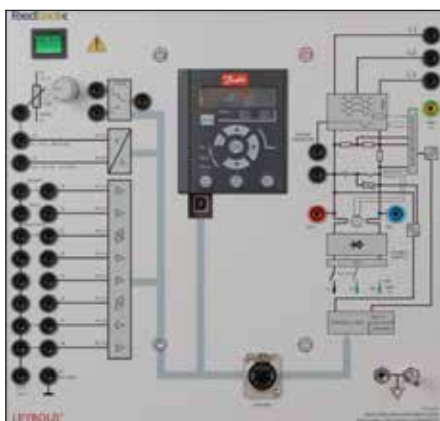

Industrial Frequency Converter

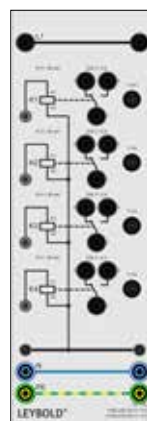

Relay 230 V / 5 A

727 115	4 Relays 230 V / 5 A
731 50	Star-delta starter
731 51	Soft starter 0.3 / 1.0
731 55	Pole reverser, Dahlander
732 13	Motor protection switch, 0.6-1 A
732 14	Motor protection switch, 1-1.6 A
732 29	Rotor starter 0.3
732 40	Resistive load 0.3
745 05	Manual synchronisation unit
773 5313	Industrial Frequency Converter



# CONTACT

130 8006EN 01.2021 LD  
Subject to technical modifications

## GERMANY:

LD DIDACTIC GmbH  
Leyboldstr. 1  
D-50354 Hürth/Germany

Tel.: +49 2233 604 0  
Fax: +49 2233 604 222  
E-Mail: [info@ld-didactic.de](mailto:info@ld-didactic.de)

[WWW.LD-DIDACTIC.COM](http://WWW.LD-DIDACTIC.COM)  
[WWW.LEYBOLD-SHOP.COM](http://WWW.LEYBOLD-SHOP.COM)

